

PS ~ Piquage express 90°

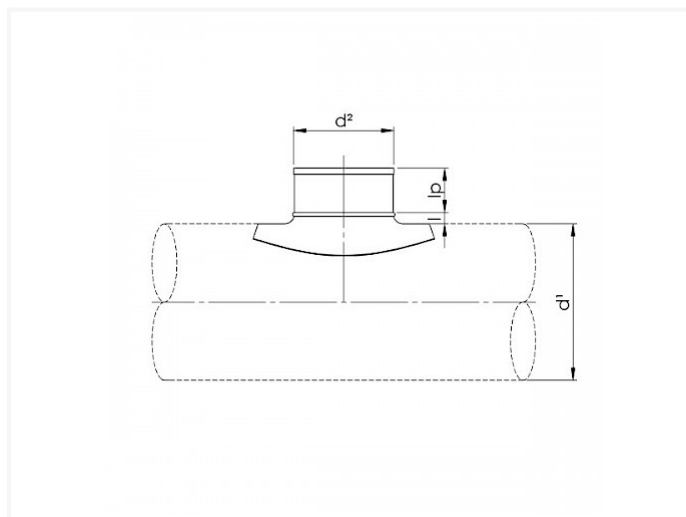

Fiche technique

DIAMETER	D1	D2	IP	I	KG	DOOS	STUKS
80 80	80	80	40	52	0.10	P12	70
100 80	100	80	40	60	0.10	P12	60
125 80	125	80	40	75	0.10	P12	60
150 80	160	80	40	92	0.09	P12	75
160 80	160	80	40	92	0.09	P12	75
180 80	200	80	40	112	0.09	P12	70
200 80	200	80	40	112	0.09	P12	70
224 80	200	80	40	124	0.09	P12	70
250 80	250	80	40	137	0.09	P12	70
280 80	250	80	40	137	0.09	P12	70
300 80	250	80	40	137	0.09	P12	70
315 80	315	80	40		0.09	P12	70
355 80	355	80	40		0.09	P12	60

DIAMETER	D1	D2	IP	I	KG	DOOS	STUKS
400 80	400	80	40		0.09	P12	60
100 100	100	100	40	65	0.14	P6	85
125 100	125	100	40	78	0.12	P6	90
150 100	160	100	40	95	0.12	P6	105
160 100	160	100	40	95	0.12	P6	105
180 100	200	100	40	115	0.12	P6	100
200 100	200	100	40	115	0.12	P6	100
224 100	200	100	40	115	0.12	P6	100
250 100	250	100	40	140	0.12	P6	100
280 100	250	100	40	140	0.12	P6	100
300 100	315	100	40	173	0.12	P6	115
315 100	315	100	40	173	0.12	P6	115
355 100	315	100	40	173	0.12	P6	115
400 100	500	100	40	265	0.12	P6	100
450 100	500	100	40	265	0.12	P6	100
500 100	500	100	40	265	0.12	P6	100
560 100	500	100	40	265	0.12	P6	100
600 100	500	100	40	265	0.12	P6	100
630 100	500	100	40	265	0.12	P6	100
125 125	125	125	40	83	0.21	P4	65
150 125	160	125	40	100	0.19	P4	85
160 125	160	125	40	100	0.19	P4	85
180 125	200	125	40	115	0.17	P4	80
200 125	200	125	40	115	0.17	P4	80
224 125	250	125	40	145	0.17	P4	105

DIAMETER	D1	D2	IP	I	KG	DOOS	STUKS
250 125	250	125	40	145	0.17	P4	105
280 125	250	125	40	145	0.17	P4	105
300 125	315	125	40	178	0.17	P4	100
315 125	315	125	40	178	0.17	P4	100
355 125	315	125	40	178	0.17	P4	100
400 125	500	125	40	220	0.15	P4	110
450 125	500	125	40	220	0.15	P4	110
500 125	500	125	40	220	0.15	P4	110
560 125	500	125	40	220	0.15	P4	110
600 125	500	125	40	220	0.15	P4	110
630 125	500	125	40	220	0.15	P4	110
150 150	150	150	40	95	0.31	P4	55
160 150	150	150	40	95	0.31	P4	55
180 150	200	150	40	120	0.27	P4	72
200 150	200	150	40	120	0.27	P4	72
224 150	250	150	40	145	0.26	P4	72
250 150	250	150	40	145	0.26	P4	72
280 150	315	150	40	178	0.26	P4	78
300 150	315	150	40	178	0.26	P4	78
315 150	315	150	40	178	0.26	P4	78
355 150	315	150	40	178	0.26	P4	78
160 160	160	160	40	105	0.34	P2	70
180 160	200	160	40	125	0.29	P4	54
200 160	200	160	40	125	0.29	P4	54
224 160	250	160	40	150	0.29	P4	68

DIAMETER	D1	D2	IP	I	KG	DOOS	STUKS
250 160	250	160	40	150	0.29	P4	68
280 160	315	160	40	182	0.27	P4	66
300 160	315	160	40	182	0.27	P4	66
315 160	315	160	40	182	0.27	P4	66
355 160	400	160	40	225	0.25	P4	66
400 160	400	160	40	225	0.25	P4	66
450 160	500	160	40	275	0.25	P4	66
500 160	500	160	40	275	0.25	P4	66
560 160	630	160	40	340	0.23	P4	66
630 160	630	160	40	340	0.23	P4	66
200 200	200	200	40	125	0.46	P2	63
224 200	250	200	40	150	0.41	P4	32
250 200	250	200	40	150	0.41	P4	32
280 200	315	200	40	182	0.41	P4	32
300 200	315	200	40	182	0.41	P4	32
315 200	315	200	40	182	0.41	P4	32
355 200	400	200	40	225	0.37	P4	38
400 200	400	200	40	225	0.37	P4	38
450 200	500	200	40	275	0.31	P4	38
500 200	500	200	40	275	0.31	P4	38
560 200	630	200	40	340	0.30	P4	38
630 200	630	200	40	340	0.30	P4	38
250 250	250	250	40	150	0.63	P2	38
280 250	315	250	40	182	0.50	P2	44
300 250	315	250	40	182	0.50	P2	44

DIAMETER	D1	D2	IP	I	KG	DOOS	STUKS	
315 250	315	250	40	182	0.50	P2	44	
355 250	400	250	40	225	0.49	P2	44	
400 250	400	250	40	225	0.49	P2	44	
450 250	500	250	40	275	0.45	P4	22	
500 250	500	250	40	275	0.45	P4	22	
560 250	630	250	40	340	0.43	P4	22	
630 250	630	250	40	340	0.43	P4	22	
315 315	315	315	40	182	0.85	P1	60	without safety edge
355 315	400	315	40		0.68	P1	66	without safety edge
400 315	400	315	40		0.68	P1	66	without safety edge
450 315	500	315	40		0.64	P1	60	without safety edge
500 315	500	315	40		0.64	P1	60	without safety edge
560 315	630	315	40		0.75	P1	60	without safety edge
630 315	630	315	40		0.75	P1	60	without safety edge
400 400	400	400						without safety edge
450 400	500	400						without safety edge
500 400	500	400						without safety edge
560 400	630	400						without safety edge
630 400	630	400						without safety edge