

PSX ~ Piquage express 90° à joint

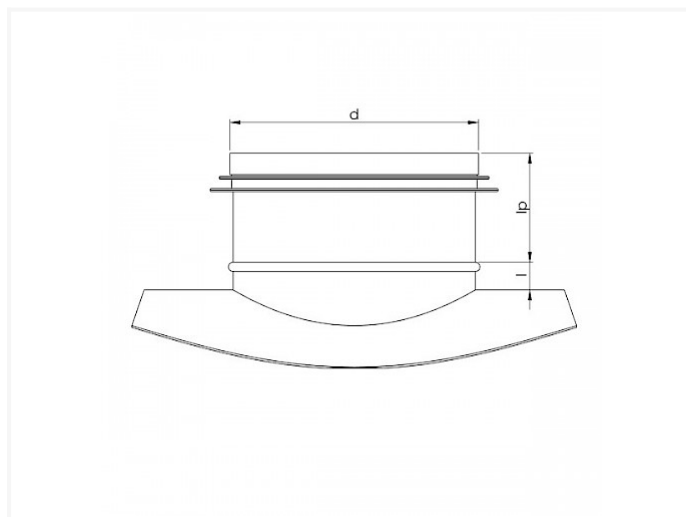

Fiche technique

DIAMETER	D1	D2	IP	I	KG	DOOS	STUKS
80 80	80	80	35		0,12	P12	60
100 80	100	80	35		0,11	P12	60
125 80	125	80	35		0,12	P12	60
150 80	160	80	35		0,11	P12	60
160 80	160	80	35		0,11	P12	60
180 80	200	80	35		0,11	P12	70
200 80	200	80	35		0,11	P12	70
224 80	200	80	35		0,11	P12	70
250 80	250	80	35		0,11	P12	60
280 80	250	80	35		0,11	P12	60
300 80	250	80	35		0,11	P12	60
315 80	315	80	35		0,11	P12	60
355 80	355	80	35		0,11	P12	60

DIAMETER	D1	D2	IP	I	KG	DOOS	STUKS
400 80	400	80	35		0,11	P12	60
100 100	100	100	35		0,12	P6	75
125 100	125	100	35		0,16	P6	90
150 100	160	100	35		0,14	P6	100
160 100	160	100	35		0,14	P6	100
180 100	200	100	35		0,13	P6	100
200 100	200	100	35		0,13	P6	100
224 100	200	100	35		0,13	P6	100
250 100	250	100	35		0,13	P6	100
280 100	250	100	35		0,13	P6	100
300 100	315	100	35		0,13	P6	115
315 100	315	100	35		0,13	P6	115
355 100	315	100	35		0,13	P6	115
400 100	500	100	35		0,13	P6	100
450 100	500	100	35		0,13	P6	100
500 100	500	100	35		0,13	P6	100
560 100	500	100	35		0,13	P6	100
600 100	500	100	35		0,13	P6	100
630 100	500	100	35		0,13	P6	100
125 125	125	125	35		0,21	P4	65
150 125	160	125	35		0,19	P4	75
160 125	160	125	35		0,19	P4	75
180 125	200	125	35		0,17	P4	75
200 125	200	125	35		0,17	P4	75
224 125	250	125	35		0,17	P4	90

DIAMETER	D1	D2	IP	I	KG	DOOS	STUKS
250 125	250	125	35		0,17	P4	90
280 125	250	125	35		0,17	P4	90
300 125	315	125	35		0,17	P4	90
315 125	315	125	35		0,17	P4	90
355 125	315	125	35		0,17	P4	90
400 125	500	125	35		0,14	P4	100
450 125	500	125	35		0,14	P4	100
500 125	500	125	35		0,14	P4	100
560 125	500	125	35		0,14	P4	100
600 125	500	125	35		0,14	P4	100
630 125	500	125	35		0,14	P4	100
150 150	150	150	35		0,36	P4	56
160 150	150	150	35		0,36	P4	56
180 150	200	150	35		0,31	P4	72
200 150	200	150	35		0,31	P4	72
224 150	250	150	35		0,29	P4	72
250 150	250	150	35		0,29	P4	72
280 150	315	150	35		0,28	P4	72
300 150	315	150	35		0,28	P4	72
315 150	315	150	35		0,28	P4	72
355 150	315	150	35		0,28	P4	72
160 160	160	160	35		0,35	P4	48
180 160	200	160	35		0,34	P4	54
200 160	200	160	35		0,34	P4	54
224 160	250	160	35		0,26	P4	62

DIAMETER	D1	D2	IP	I	KG	DOOS	STUKS
250 160	250	160	35		0,26	P4	62
280 160	315	160	35		0,26	P4	66
300 160	315	160	35		0,26	P4	66
315 160	315	160	35		0,26	P4	66
355 160	400	160	35		0,27	P4	66
400 160	400	160	35		0,27	P4	66
450 160	500	160	35		0,27	P4	66
500 160	500	160	35		0,27	P4	66
200 200	200	200	35		0,51	P2	64
224 200	250	200	35		0,46	P4	32
250 200	250	200	35		0,46	P4	32
280 200	315	200	35		0,47	P4	32
300 200	315	200	35		0,47	P4	32
315 200	315	200	35		0,47	P4	32
355 200	400	200	35		0,36	P4	38
400 200	400	200	35		0,36	P4	38
450 200	500	200	35		0,33	P4	38
500 200	500	200	35		0.33	P4	38
560 200	630	200	35		0.32	P4	38
630 200	630	200	35		0.32	P4	38
250 250	250	250	35		0,73	P2	38
280 250	315	250	35		0,58	P2	40
300 250	315	250	35		0,58	P2	40
315 250	315	250	35		0,58	P2	40
355 250	400	250	35		0,57	P2	44

DIAMETER	D1	D2	IP	I	KG	DOOS	STUKS
400 250	400	250	35		0,57	P2	44
450 250	500	250	35		0.49	P4	22
500 250	500	250	35		0.49	P4	22
560 250	630	250	35		0.47	P4	22
630 250	630	250	35		0.47	P4	22
315 315	315	315	35		0,97	P1	48
355 315	400	315	35		0.79	P1	54
400 315	400	315	35		0,79	P1	54
450 315	500	315	35		0.68	P1	60
500 315	500	315	35		0.68	P1	60
560 315	630	315	35		0.79	P1	60
630 315	630	315	35		0.79	P1	60
400 400	400	400	35		1.02	P1	20
450 400	500	400	35		1.30	P1	14
500 400	500	400	35		1.30	P1	14
560 400	630	400	35		1.22		
630 400	630	400	35		1.22	P1	18