

# TLX ~ Pieza Tee soldada a 90° con goma

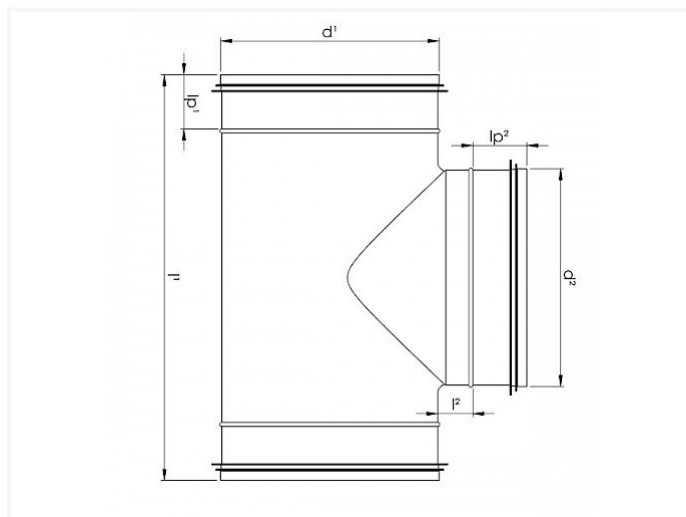

## Data técnica

DIÁMETRO	D1	D2	l1	l2	IP1	IP2	KG	CAJA	PIEZAS
100 80	100	80	227	22	35	35	0.35	P2	84
125 80	125	80	225	22	35	35	0.42	P2	60
100 100	100	100	227	22	35	35	0.39	P2	84
125 100	125	100	223	20	35	35	0.47	P2	60
150 100	150	100	227	20	35	35	0.55	P2	40
160 100	160	100	227	20	35	35	0.58	P1	78
200 100	200	100	227	20	35	35	0.72	P1	48
250 100	250	100	227	20	35	35	1.00	P1	33
125 125	125	125	252	20	35	35	0.52	P2	54
150 125	150	125	252	20	35	35	0.62	P2	35
160 125	160	125	252	24	35	35	0.64	P1	72
200 125	200	125	252	20	35	35	0.78	P1	48
250 125	250	125	252	20	35	35	1.11	P1	33

DIÁMETRO	D1	D2	I1	I2	IP1	IP2	KG	CAJA	PIEZAS
150 150	150	150	277	20	35	35	0.68	P2	30
160 160	160	160	286	20	35	35	0.71	P1	60
200 160	200	160	286	20	35	35	0.91	P1	40
250 160	250	160	286	22	35	35	1.22	P1	24
200 200	200	200	328	20	35	35	1.00	P1	35
250 200	250	200	324	22	35	35	1.37	P1	22
250 250	250	250	373	25	35	35	1.59	P1	22
315 315	315	315	438	25	35	35	2.27	P1	10