

# B4X ~ Gepresste Bögen 45° mit Lippendichtung

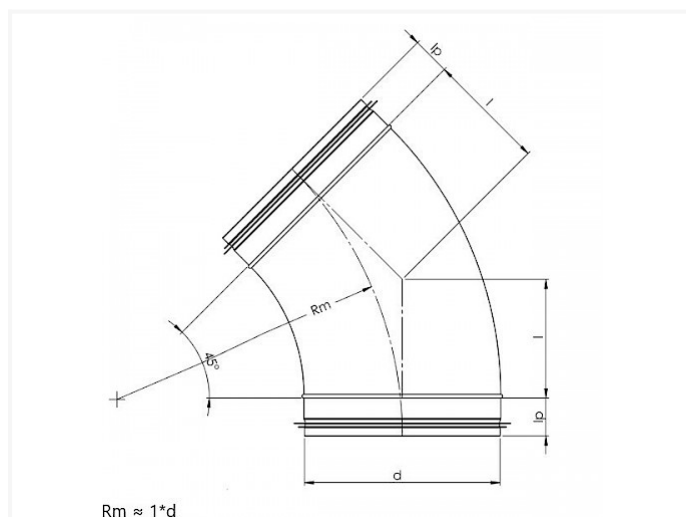

## Technische Daten

DURCHMESSER D	l	KG	KARTON	STÜCK
80*	41	0,15	P6	90
100	41	0,20	P4	90
112	49	0,23	P6	44
125	51	0,27	P2	100
140	55	0,34	P6	25
150	62	0,36	P2	60
160	66	0,41	P1	110
180	74	0,49	P1	80
200	82	0,58	P1	60
224	92	0,84	P1	45
250	103	1,07	P1	32

\* Ausnahme:  $R_m$  B4X 80 =  $1,25 \cdot d$